

Cutting Data for Aluminium

2061 / 2022 / 2082 / 180-10 /
2001-H / 2001 / 2031 / 2051 / 2081 / 3001
Cyber Full Width x 0.25D

DIAMETER	FEED PER TOOTH (mm)	SPINDLE SPEED R.P.M.
3mm	0.03	max. available
4mm	0.04	max. available
5mm	0.05	max. available
6mm	0.06	max. available
8mm	0.08	max. available
10mm	0.10	max. available
12mm	0.15	max. available
16mm	0.16	max. available
20mm	0.20	max. available

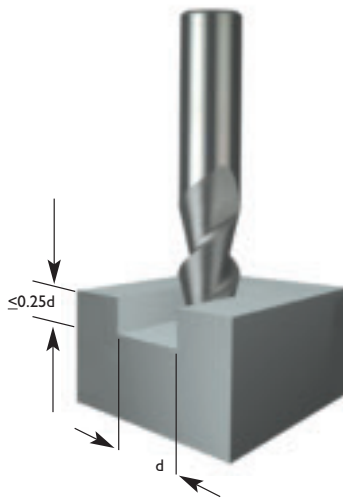

2041 / 2052 Series Cyber End Mill Data

DIAMETER	FEED PER TOOTH (mm)	SPINDLE SPEED R.P.M.
3mm	0.03	max. available
4mm	0.05	max. available
6mm	0.06	max. available
8mm	0.08	max. available
10mm	0.10	max. available
12mm	0.15	max. available
16mm	0.16	max. available
20mm	0.20	max. available

3041 / 3051 Series Cyber End Mill Data

DIAMETER	FEED PER TOOTH (mm)	SPINDLE SPEED R.P.M.
3mm	0.03	max. available
4mm	0.05	max. available
6mm	0.06	max. available
8mm	0.08	max. available
10mm	0.10	max. available
12mm	0.15	max. available
16mm	0.16	max. available
20mm	0.20	max. available

Series 3051 Reduce Feed by 40%

501 I Series Cyber End Mill Data

DIAMETER	FEED PER TOOTH (mm)	SPINDLE SPEED R.P.M.
3mm	0.03	max. available
4mm	0.05	max. available
6mm	0.06	max. available
8mm	0.08	max. available
10mm	0.10	max. available
12mm	0.15	max. available
16mm	0.16	max. available
20mm	0.20	max. available

